



**FT85011/FR85011
Fiber Transmitter
and Receiver**



**Single-Channel Digitally Encoded Video
with Bidirectional Data**

C1642M-A (1/05)

Contents

Regulatory Notices	4
Important Safety Instructions	5
Product Overview	7
Description	7
Models	9
Optional Accessories	9
Front Panel	10
Rear Panel	11
Installation	12
Package Contents	12
Data Communication Setup	12
Mounting	13
Mounting the Transmitter/Receiver into a Rack	14
Mounting the Transmitter/Receiver to a Wall	14
Connections	16
Troubleshooting	24
Specifications	28

List of Illustrations

1	FT85011 Transmitter and FR85011 Receiver Single-Channel Video and Data Applications	7
2	Front Panel of FT85011 Transmitter and FR85011 Receiver	10
3	Rear Panel of FT85011 Transmitter and FR85011 Receiver	11
4	Data Selection Switch	12
5	Mounting the FT85011 Transmitter/FR85011 Receiver Using the Wall Clip	15
6	FT85011 Transmitter/FR85011 Receiver Connections	16
7	RS-232 Data Communication Wiring	18
8	RS-422 Data Communication Wiring	19
9	RS-485 2-Wire (Half Duplex) Data Communication Wiring	20
10	RS-485 4-Wire (Full Duplex) Data Communication Wiring	21
11	Manchester Data Communication Wiring	22
12	Bi-Phase Data Communication Wiring	23

List of Tables

A	Data Communication Switch Settings	13
B	Data Connector Pin Assignments	17
C	Troubleshooting with Front-Panel Indicators	24

Regulatory Notices

This device complies with Part 15 of the FCC Rules. Operation is subject to the following two conditions: (1) this device may not cause harmful interference, and (2) this device must accept any interference received, including interference that may cause undesired operation.

RADIO AND TELEVISION INTERFERENCE

This equipment has been tested and found to comply with the limits of a Class B digital device, pursuant to Part 15 of the FCC Rules. These limits are designed to provide reasonable protection against harmful interference in a residential installation. This equipment generates, uses, and can radiate radio frequency energy and, if not installed and used in accordance with the instructions, may cause harmful interference to radio communications. However there is no guarantee that the interference will not occur in a particular installation. If this equipment does cause harmful interference to radio or television reception, which can be determined by turning the equipment off and on, the user is encouraged to try to correct the interference by one or more of the following measures:

- Reorient or relocate the receiving antenna.
- Increase the separation between the equipment and the receiver.
- Connect the equipment into an outlet on a circuit different from that to which the receiver is connected.
- Consult the dealer or an experienced radio/TV technician for help.

You may also find helpful the following booklet, prepared by the FCC: "How to Identify and Resolve Radio-TV Interference Problems." This booklet is available from the U.S. Government Printing Office, Washington D.C. 20402.

Changes and Modifications not expressly approved by the manufacturer or registrant of this equipment can void your authority to operate this equipment under Federal Communications Commission's rules.

This Class B digital apparatus complies with Canadian ICES-003.

Cet appareil numérique de la classe B est conforme à la norme NMB-003 du Canada.

Important Safety Instructions

1. Read these instructions.
2. Keep these instructions.
3. Heed all warnings.
4. Follow all instructions.
5. Do not use this apparatus near water.
6. Clean only with dry cloth.
7. Do not block any ventilation openings. Install in accordance with the manufacturer's instructions.
8. Do not install near any heat sources such as radiators, heat registers, stoves, or other apparatus (including amplifiers) that produce heat.
9. Do not defeat the safety purpose of the polarized or grounding-type plug. A polarized plug has two blades with one wider than the other. A grounding plug has two blades and a third grounding prong. The wide blade or the third prong are provided for your safety. If the provided plug does not fit into your outlet consult an electrician for replacement of the obsolete outlet.
10. Protect the power cord from being walked on or pinched particularly at plugs, convenience receptacles, and the points where they exit from the apparatus.
11. Only use attachments/accessories specified by the manufacturer.
12. Use only with the cart, stand, tripod, bracket, or table specified by the manufacturer, or sold with the apparatus. When a cart is used, use caution when moving the cart/apparatus combination to avoid injury from tip-over.
13. Unplug this apparatus during lightning storms or when unused for long periods of time.
14. Refer all servicing to qualified service personnel. Servicing is required when the apparatus has been damaged in any way, such as power-supply cord or plug is damaged, liquid has been spilled or objects have fallen into the apparatus, the apparatus has been exposed to rain or moisture, does not operate normally, or has been dropped.
15. Apparatus shall not be exposed to dripping or splashing and that no objects filled with liquids, such as vases shall be placed on the apparatus.
16. **WARNING:** To reduce the risk of fire or electric shock, do not expose this apparatus to rain or moisture.
17. Installation should be done only by qualified personnel and conform to all local codes.
18. Unless the unit is specifically marked as a NEMA Type 3, 3R, 3S, 4, 4X, 6, or 6P enclosure, it is designed for indoor use only and it must not be installed where exposed to rain and moisture.
19. Use only installation methods and materials capable of supporting four times the maximum specified load.

CAUTION: These servicing instructions are for use by qualified service personnel only. To reduce the risk of electric shock do not perform any servicing other than that contained in the operating instructions unless you are qualified to do so.

The product and/or manual may bear the following marks:

 This symbol indicates that dangerous voltage constituting a risk of electric shock is present within this unit.

 This symbol indicates that there are important operating and maintenance instructions in the literature accompanying this unit.

CAUTION:
RISK OF ELECTRIC SHOCK. DO NOT OPEN.

Product Overview

DESCRIPTION

The FT85011/FR85011 fiber transmitter and receiver provide the ability to transmit one unidirectional composite video channel and one bidirectional data channel over one optical fiber. In addition, patent-pending technology provides the solution for allowing Coaxitron® pan/tilt/zoom (PTZ) control data to be transmitted the full distance of the fiber (up to 6 km for multimode fiber and up to 30 km for single-mode fiber). Figure 1 illustrates FT85011 transmitter and FR85011 receiver single-channel video and data applications.

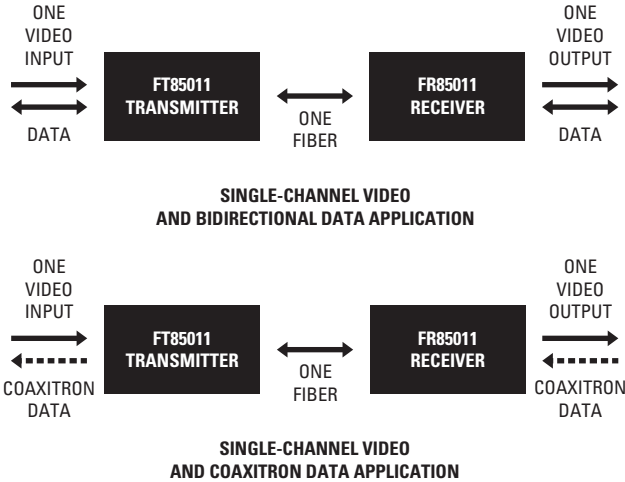

Figure 1. FT85011 Transmitter and FR85011 Receiver Single-Channel Video and Data Applications

Features of the FT85011/FR85011 fiber optic transmission system include the following:

- 8-bit digitally encoded video for high-quality video transmission over a single fiber
- Bidirectional data channel that supports RS-232, RS-422, RS-485 (2-wire/4-wire), Manchester, Bi-Phase, and Coaxitron communication
- Patent-pending transmission technology allowing for Coaxitron control at full-distance capabilities
- Integrated wavelength division multiplexing (WDM), allowing video and data channels to be transmitted in the same fiber using different wavelengths
- Multimode fiber support for distances up to 6 km
- Single-mode fiber support for distances up to 30 km
- Exceeds all requirements for the RS-250C Medium-Haul Transmission specification
- Compatible with NTSC, PAL, and SECAM video standards
- No performance adjustments required
- 12 VDC or 24 VAC power supply

- Standalone and rack-mountable modular design
- LED indicators for monitoring of signal status, data activity, and operating power

 **NOTES:**

- The FT85011 transmitter/FR85011 receiver is a Class 1 laser product that complies with FDA radiation performance standard 21CFR Subchapter J and with IEC 60825-1 Edition 1.2, 2001-08.
- In addition to compatibility with the FT85011 transmitter, the FR85011 receiver is also compatible with the FS85011 transmitter, which can be used in a Spectra III™ dome and in an ExSite™ explosionproof positioning system. For additional information about the FS85011 transmitter, refer to the FS85011 Fiber Transmitter Installation manual.

MODELS

The FT85011/FR85011 fiber transmitter and receiver consist of the following series of models:

Multimode Models:

FT85011MSTR	Single-channel fiber optic video transmitter/data transceiver; multimode, ST connector
FR85011MSTR	Single-channel fiber optic video receiver/data transceiver; multimode, ST connector

Single-Mode Models:

FT85011SSTR	Single-channel fiber optic video transmitter/data transceiver; single-mode, ST connector
FR85011SSTR	Single-channel fiber optic video receiver/data transceiver; single-mode, ST connector
FT85011SFCR	Single-channel fiber optic video transmitter/data transceiver; single-mode, FC connector
FR85011SFCR	Single-channel fiber optic video receiver/data transceiver; single-mode, FC connector

OPTIONAL ACCESSORIES

The following optional accessories are available:

WM5001-3U	Wall mount base kit for single-width module
WM5001-3UEXP	Wall mount expansion kit for single-width module
RK5000-3U	19-inch rack mount chassis for 14 slots (no power), 3 RUs
RK5000PS-3U	19-inch rack mount chassis for 12 slots with power, 3 RUs
EPS5000-120	External/redundant power supply, 1 RU, 120 W x 2
RK5001B-3U	Blank filler panel, single width
RK5002B-3U	Blank filler panel, double width

FRONT PANEL

The front panel of the FT85011 transmitter and the FR85011 receiver provides LED indicators that allow you to monitor data activity, signal status, and operating power (refer to Figure 2).

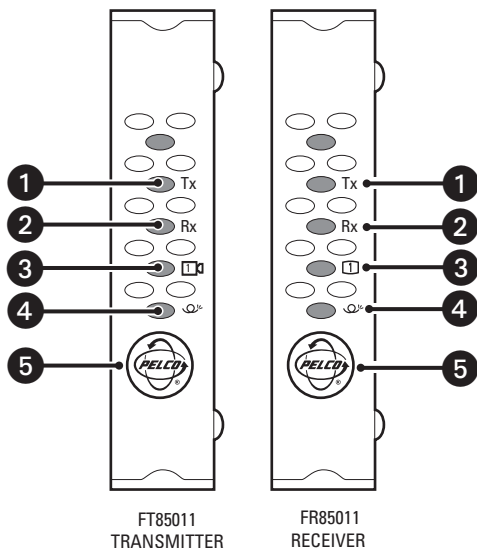

Figure 2. Front Panel of FT85011 Transmitter and FR85011 Receiver

- 1 DATA TX LED
- 2 DATA RX LED
- 3 VIDEO PRESENT LED
- 4 CARRIER DETECT LED
- 5 POWER LED (Pelco badge)

For detailed information about the front-panel indicators, refer to the *Troubleshooting* section.

REAR PANEL

All connections to the FT85011 transmitter and FR85011 receiver are made to the rear panel of the modules (refer to Figure 3).

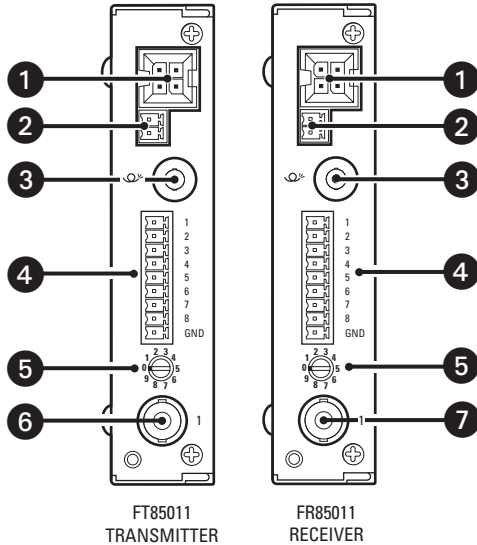

Figure 3. Rear Panel of FT85011 Transmitter and FR85011 Receiver

- ❶ RACK POWER/ALARM CONNECTOR, 4-pin connector for power/alarm connection of rack-mounted module
- ❷ STANDALONE POWER CONNECTOR, 2-pin connector for power connection of standalone module; removable mating connector with screw terminals (not shown)
- ❸ FIBER OPTIC CONNECTOR, ST or FC (dependent on FT85011/FR85011 model)
- ❹ DATA CONNECTOR, 9-pin connector; removable mating connector with screw terminals (not shown)
- ❺ DATA SELECTION SWITCH, 10-position rotary switch
- ❻ VIDEO IN CONNECTOR, 75-ohm BNC analog video input (*transmitter only*)
- ❼ VIDEO OUT CONNECTOR, 75-ohm BNC analog video output (*receiver only*)

For additional information about rear-panel connections and about the Data Selection switch, refer to the *Installation* section.

Installation

PACKAGE CONTENTS

The following items are supplied:

- **With the FT85011 transmitter:**
 - 1 Regulated switching power supply with four plug adapters (North American, Australian, U.K., and European configurations); 100-240 VAC input, 12 VDC output
 - 1 Wall clip with two 4-40 x .250-inch Phillips pan head screws with lock washers (for attachment of single module to wall)
 - 1 FT85011/FR85011 Fiber Transmitter and Receiver Installation manual (this manual)
- **With the FR85011 receiver:**
 - 1 Regulated switching power supply with four plug adapters (North American, Australian, U.K., and European configurations); 100-240 VAC input, 12 VDC output
 - 1 Wall clip with two 4-40 x .250-inch Phillips pan head screws with lock washers (for attachment of single module to wall)
 - 1 FT85011/FR85011 Fiber Transmitter and Receiver Installation manual (this manual)

DATA COMMUNICATION SETUP

NOTE: As a matter of convenience, it is recommended that you set the desired data communication before mounting the FT85011 transmitter/FR85011 receiver into a rack or onto a wall.

The Data Selection switch, which is located on the rear panel of the FT85011 transmitter/FR85011 receiver, is a 10-position rotary switch that allows you to set the data communication required for the transfer of data (refer to Figure 4).

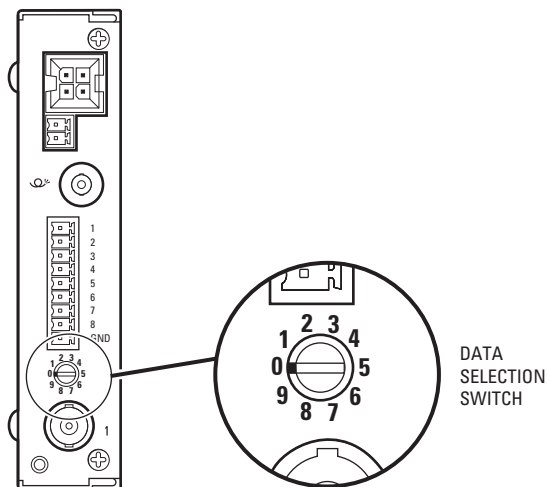

Figure 4. Data Selection Switch

With the FT85011 transmitter/FR85011 receiver powered off, set the Data Selection switch to the required data communication using a small screwdriver. Refer to Table A for data communication switch settings.

Table A. Data Communication Switch Settings

Data Communication	Switch Setting
RS-232	0 (default setting)
RS-422	1
RS-485 2-Wire	2
RS-485 4-Wire	3
Manchester/Bi-Phase	4
Coaxitron	5
Not used	6-9

Note the following:

- The FT85011 transmitter/FR85011 receiver allows data translation between RS-232 and RS-422 signal levels. Consequently, the Data Selection switch can be set to 0 (RS-232) on the transmitter and to 1 (RS-422) on the receiver. Conversely, the Data Selection switch can be set to 1 (RS-422) on the transmitter and to 0 (RS-232) on the receiver.
- If you wish to change the data communication setting after the FT85011 transmitter/FR85011 receiver has been powered on, power off the transmitter/receiver, change the data communication setting, and then power on the transmitter/receiver again.

MOUNTING

The FT85011 transmitter/FR85011 receiver can be mounted into a rack or can be used as a standalone module. As a standalone module, the unit can be placed on a desktop or can be mounted to a wall.



NOTE: As a matter of convenience, it is recommended that you set the desired data communication before mounting the FT85011 transmitter/FR85011 receiver. To set the desired data communication, refer to the *Data Communication Setup* section.

MOUNTING THE TRANSMITTER/RECEIVER INTO A RACK

Optional fiber rack mount chassis, which can be mounted into an industry-standard 19-inch (48.26 cm) equipment rack, are designed for installation of multiple modules:

- The RK5000PS-3U fiber rack mount chassis provides 12 module slots and a power supply.
- The RK5000-3U fiber rack mount chassis provides 14 module slots (a power supply is not included). Power to the modules can be supplied using the optional external power supply (EPS5000-120).

For additional information, refer to the RK5000PS-3U/RK5000-3U Fiber Rack Mount Chassis Installation manual.

MOUNTING THE TRANSMITTER/RECEIVER TO A WALL

The FT85011 transmitter/FR85011 receiver can be mounted to a wall in the following ways:

- Using the supplied wall clip for attachment of a single module to a wall. For installation instructions, refer to the *Mounting the Transmitter/Receiver Using the Wall Clip* section.
- Using the optional fiber wall mount kits for a maximum of three modules to be attached to a wall. The optional WM5001-3U wall mount base kit allows attachment of a single module to a wall. Up to two WM5001-3UEXP wall mount expansion kits can be used to allow attachment of two additional modules to the wall. For additional information, refer to the Fiber Wall Mount Kits Installation manual.

Mounting the Transmitter/Receiver Using the Wall Clip

 **NOTE:** Before mounting the FT85011 transmitter/FR85011 receiver to a wall, ensure that there is adequate space at both ends for viewing the front-panel LEDs and for making the various rear-panel cable connections.

To attach the FT85011 transmitter/FR85011 receiver to a wall using the supplied wall clip, refer to Figure 5 and do the following:

1. Using the two vertical or horizontal wall-mounting holes, attach the wall clip to a wall using two screws (not provided).
2. Slide the module into the clip until the two holes on the bottom of the module align with the two holes on the lower flange of the clip.
3. Attach the module to the clip using the two Phillips pan head screws provided for the clip.

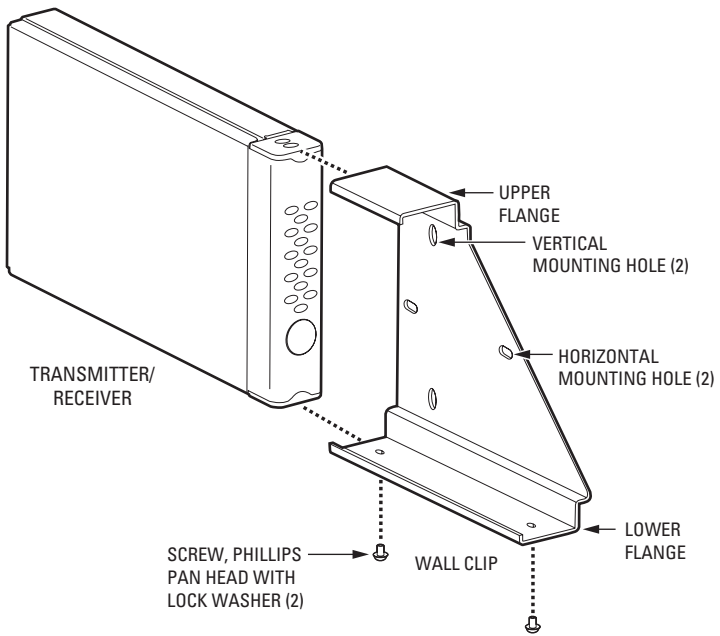

Figure 5. Mounting the FT85011 Transmitter/FR85011 Receiver Using the Wall Clip

CONNECTIONS

Connections to the FT85011 transmitter and the FR85011 receiver are made on the rear panel of the modules and consist of the following:

- Power connection

NOTE: A 12 VDC or 24 VAC power supply can be used to power the transmitter/receiver when used as a standalone module. A 12 VDC power supply is provided. If a 24 VAC power supply is used, the power supply must be a Listed Direct Plug-In Power Unit marked as Class 2 and rated as 24 VAC, 200 mA (minimum output).

- Fiber connection
- Data connection
- Video input connection (transmitter only)
- Video output connection (receiver only)

Figure 6 provides an illustration of FT85011 transmitter/FR85011 receiver connections.

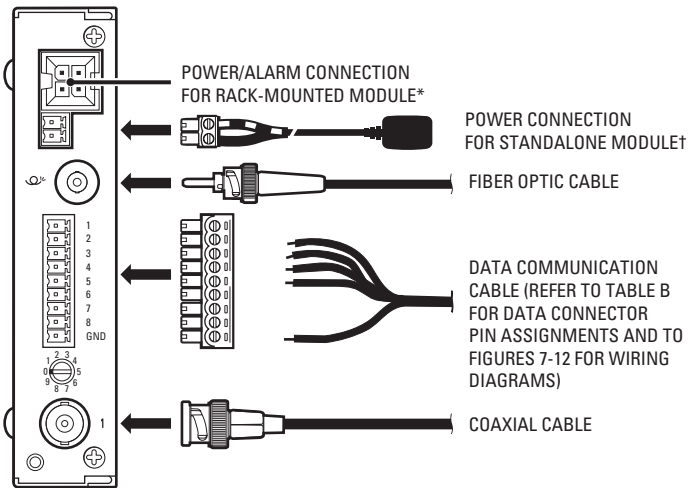

*REFER TO THE RK5000PS-3U/RK5000-3U FIBER RACK MOUNT CHASSIS INSTALLATION MANUAL FOR INFORMATION.

†THE STRIPED WIRE OF THE SUPPLIED 12 VDC POWER SUPPLY CONNECTS TO THE PIN 1 SCREW TERMINAL (DC+) OF THE STANDALONE POWER CONNECTOR. THE OTHER WIRE CONNECTS TO THE PIN 2 SCREW TERMINAL (DC-).

Figure 6. FT85011 Transmitter/FR85011 Receiver Connections

Table B. Data Connector Pin Assignments

Pin Number	RS-232	RS-422	RS-485 2-Wire	RS-485 4-Wire	Manchester	Bi-Phase
1	—	Out+	In+/Out+	Out+	—	—
2	—	Out-	In-/Out-	Out-	—	—
3	—	In+	—	In+	In+ (W)	In+
4	—	In-	—	In-	In- (B)	In-
5	In	—	—	—	—	—
6	Out	—	—	—	—	—
7	—	—	—	—	Out+ (W)	Out+
8	—	—	—	—	Out- (B)	Out-
9	Ground	—*	—*	—*	Shield	Shield

*Ground may be required based on conditions of installation. Refer to the current version of EIA/TIA-422 and EIA/TIA-485 for additional information.

NOTES:

- In, In+, and In- denote data input to the transmitter/receiver.
- Out, Out+, and Out- denote data output from the transmitter/receiver.
- W denotes white wire, and B denotes black wire.

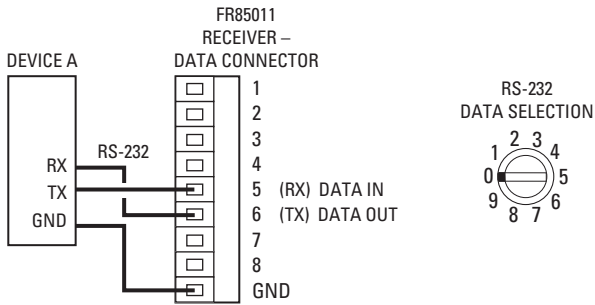

RS-232 DATA CONNECTIONS BETWEEN DEVICE A AND FR85011 RECEIVER

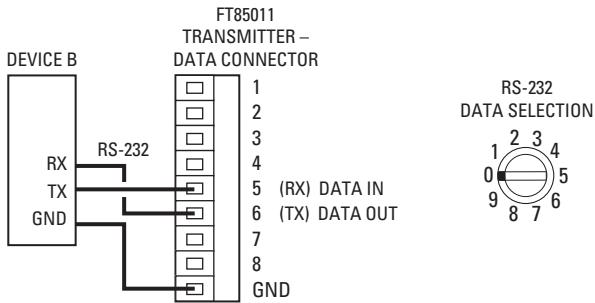

RS-232 DATA CONNECTIONS BETWEEN DEVICE B AND FT85011 TRANSMITTER

Figure 7. RS-232 Data Communication Wiring

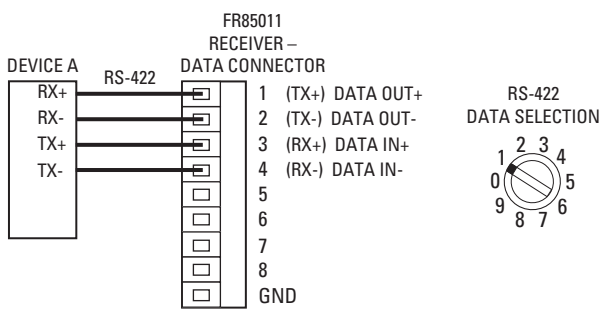

RS-422 DATA CONNECTIONS BETWEEN DEVICE A AND FR85011 RECEIVER

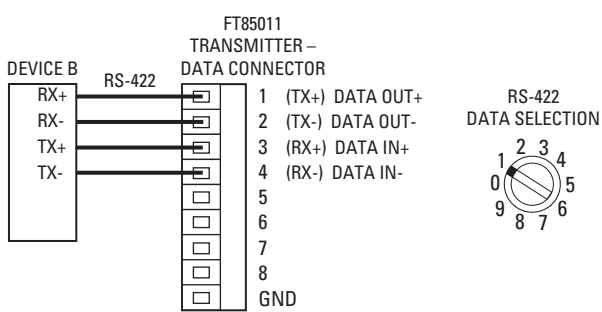

RS-422 DATA CONNECTIONS BETWEEN DEVICE B AND FT85011 TRANSMITTER

Figure 8. RS-422 Data Communication Wiring

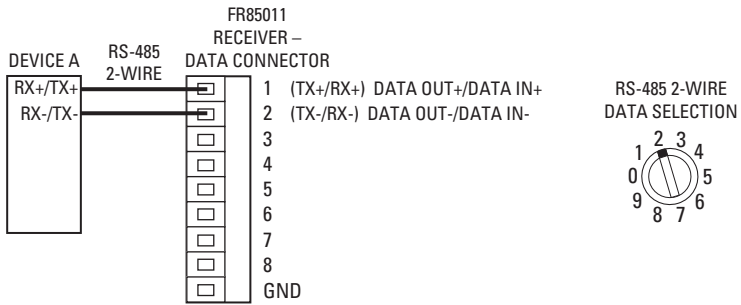

RS-485 2-WIRE DATA CONNECTIONS BETWEEN DEVICE A AND FR85011 RECEIVER

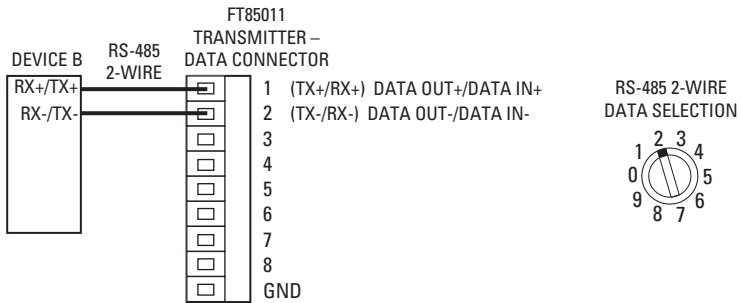

RS-485 2-WIRE DATA CONNECTIONS BETWEEN DEVICE B AND FT85011 TRANSMITTER

Figure 9. RS-485 2-Wire (Half Duplex) Data Communication Wiring

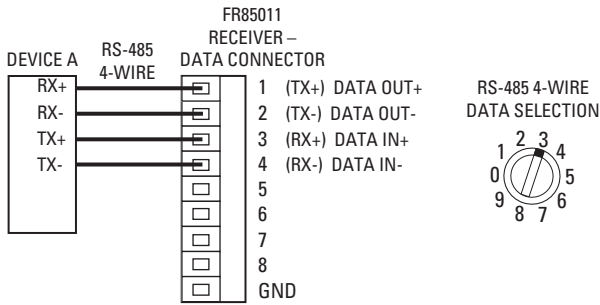

RS-485 4-WIRE DATA CONNECTIONS BETWEEN DEVICE A AND FR85011 RECEIVER

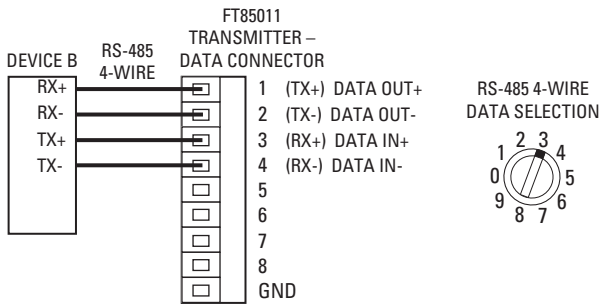

RS-485 4-WIRE DATA CONNECTIONS BETWEEN DEVICE B AND FT85011 TRANSMITTER

Figure 10. RS-485 4-Wire (Full Duplex) Data Communication Wiring

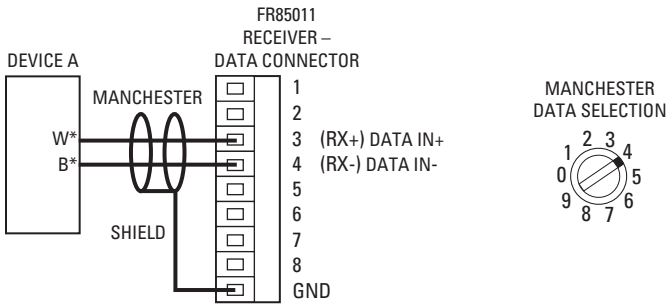

MANCHESTER DATA CONNECTIONS BETWEEN DEVICE A AND FR85011 RECEIVER

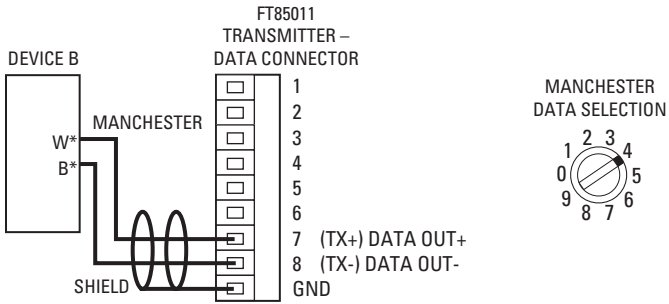

MANCHESTER DATA CONNECTIONS BETWEEN DEVICE B AND FT85011 TRANSMITTER

*W DENOTES WHITE WIRE, AND B DENOTES BLACK WIRE.

Figure 11. Manchester Data Communication Wiring

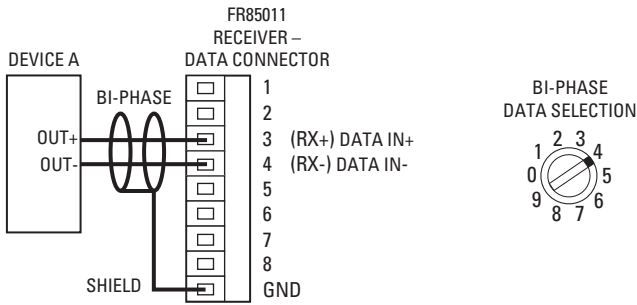

BI-PHASE DATA CONNECTIONS BETWEEN DEVICE A AND FR85011 RECEIVER

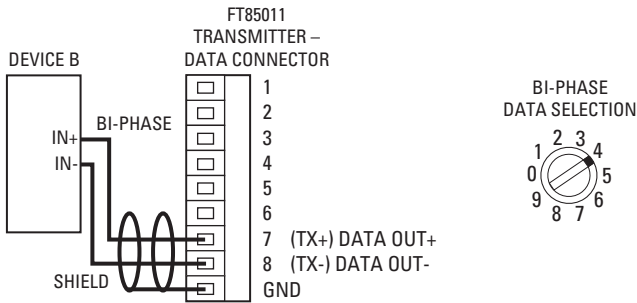

BI-PHASE DATA CONNECTIONS BETWEEN DEVICE B AND FT85011 TRANSMITTER

Figure 12. Bi-Phase Data Communication Wiring

Troubleshooting

LED indicators on the front panel of the FT85011 transmitter/FR85011 receiver (refer to Figure 2) allow you to monitor signal status, data activity, and operating power. Table C provides information about the front-panel indicators and associated troubleshooting guidelines.

Table C. Troubleshooting with Front-Panel Indicators

Indicator Color	Meaning	Possible Cause	Corrective Action
Power LED (Pelco badge)			
Blue Pelco logo lights.	Power is being applied to the module.	—	No action required.
Blue Pelco logo does not light.	Power is not being applied to the module.	Power connection is faulty.	Check power connection. If module is rack mounted, reseal module or power supply as necessary.
		Power supply has failed.	Replace power supply.
		Loss of power occurs due to tripped circuit breaker(s), blown fuse(s), or faulty electrical service.	Check circuit breaker(s), fuse(s), or electrical service as necessary.
Video Present LED			
Green	Incoming video signal is present on the channel.	—	No action required.
Red on transmitter	Incoming video signal is not present on the channel.	Video source is not powered on.	Check power connection to the video source.
		Video source is not connected to the transmitter.	Check BNC connections.
		Coaxial cable is defective.	Replace cable.

(Continued on next page)

Table C. Troubleshooting with Front-Panel Indicators (Continued)

Indicator Color	Meaning	Possible Cause	Corrective Action
Video Present LED (Continued)			
Red on receiver	Incoming video signal is not present on the channel.	Optical signal is not being received from the transmitter. Carrier Detect LED is also red.	Refer to the Carrier Detect LED troubleshooting section below.
		Video source is not powered on.	Check power connection to the video source.
		Video source is not connected to the transmitter.	Check BNC connections.
		Coaxial cable connected to the transmitter is defective.	Replace cable.
Carrier Detect LED			
Green on transmitter	The optical signal is being received from the receiver.	—	No action required.
Green on receiver	The optical signal is being received from the transmitter.	—	No action required.
Red on transmitter	The optical signal is not being received from the receiver.	Receiver is not powered on.	Check power connections. Replace power supply if necessary.
		Fiber optic cable is not connected.	Check fiber optic connections.
		Fiber optic cable connectors are dirty or are damaged.	Clean, polish, or replace fiber optic cable connectors as necessary.
		Fiber optic cable is defective.	Replace cable.

(Continued on next page)

Table C. Troubleshooting with Front-Panel Indicators (Continued)

Indicator Color	Meaning	Possible Cause	Corrective Action
Carrier Detect LED (Continued)			
Red on transmitter (continued)		A problem exists with the optical power budget.	Verify that losses in fiber optic cable do not exceed the optical power budget specification of the fiber optic link. If the losses do exceed the optical power budget, contact Product Support.
Red on receiver	The optical signal is not being received from the transmitter.	Transmitter is not powered on.	Check power connections. Replace power supply if necessary.
		Fiber optic cable is not connected.	Check fiber optic connections.
		Fiber optic cable connectors are dirty or are damaged.	Clean, polish, or replace fiber optic cable connectors as necessary.
		Fiber optic cable is defective.	Replace cable.
		A problem exists with the optical power budget.	Verify that losses in fiber optic cable do not exceed the optical power budget specification of the fiber optic link. If the losses do exceed the optical power budget, contact Product Support.

(Continued on next page)

Table C. Troubleshooting with Front-Panel Indicators (Continued)

Indicator Color	Meaning	Possible Cause	Corrective Action
Data Tx LED			
Flashing amber	Data is being transmitted onto the fiber by the data port.	—	No action required.
Red	Data Selection switch is set to an invalid setting.	Data Selection switch is set to setting 6, 7, 8, or 9.	Set Data Selection switch to the correct setting for the desired data communication (refer to Table A).
Not lit	Data is not being transmitted onto the fiber by the data port.	Data is not present on the channel.	No action required.
		Data connection is faulty.	Check data connections.
		Data communication cable is defective.	Replace cable.
Data Rx LED			
Flashing amber	Data is being received from the fiber by the data port.	—	No action required.
Red	Data Selection switch is set to an invalid setting.	Data Selection switch is set to setting 6, 7, 8, or 9.	Set Data Selection switch to the correct setting for the desired data communication (refer to Table A).
Not lit	Data is not being received from the fiber by the data port.	Data is not present on the channel.	No action required.
		Data connection is faulty.	Check data connections.
		Data communication cable is defective.	Replace cable.

Specifications

VIDEO

Number of Channels	1
Modulation Type	Pulse code modulation, 8-bit resolution
Video Input	1.0 V _{p-p} , 75 ohms; NTSC, PAL, and SECAM
Bandwidth	6.5 MHz
Gain	Unity
Differential Gain	<2%
Differential Phase	<1°
Tilt	<1%
Signal-to-Noise Ratio	>60 dB (CCIR weighted)

DATA

Number of Channels	1
Data Communication	RS-232, RS-422, RS-485 (2-wire/4-wire), Manchester, Bi-Phase, Coaxitron
Maximum Baud Rate	500 kbps

GENERAL

Operating Temperature	-40° to 167°F (-40° to 75°C)
Input Power Requirements	12 VDC or 24 VAC, 200 mA
LED Indicators	Power Video Present Carrier Detect Data Tx Data Rx
Dimensions	8.75" D x 1.08" W x 4.81" H 22.23 x 2.74 x 12.22 cm
Unit Weight	1.48 lb (0.67 kg)

MECHANICAL

Connectors	
Video	BNC
Rack Power/Alarm	4-pin connector
Standalone Power	2-pin connector, screw terminal
Data	9-pin connector, screw terminal
Fiber Optic	ST for multimode fiber ST or FC for single-mode fiber

OPTICAL POWER BUDGET, TRANSMISSION DISTANCE, AND LASER CLASS 1 LIMIT

Fiber	Wavelength	Optical Power Budget	Maximum Transmission Distance	Laser Class 1 Limit*
Multimode	1310 nm (video)	20 dB [†]	6 km (3.7 mi) [‡]	<15.6 mW
	850 nm (data)	20 dB [†]	6 km (3.7 mi) [‡]	<0.78 mW
Single-mode	1310 nm (video)	20 dB	30 km (18.6 mi) [§]	<15.6 mW
	1550 nm (data)	20 dB	30 km (18.6 mi) [§]	<10.0 mW

*The FT85011 transmitter/FR85011 receiver is classified by the FDA as a Class 1 laser product.

[†]Optical power budget is specified using 62.5/125 μ m fiber. When using 50/125 μ m fiber, subtract 4 dB from the optical power budget.

[‡]Maximum transmission distance is limited by fiber bandwidth.

[§]Maximum transmission distance is based on attenuation of 0.5 dB/km plus a 5 dB buffer for connector and splice losses.

PRODUCT WARRANTY AND RETURN INFORMATION

WARRANTY

Pelco will repair or replace, without charge, any merchandise proved defective in material or workmanship **for a period of one year** after the date of shipment.

Exceptions to this warranty are as noted below:

- Five years on FT/FR8000 Series fiber optic products and the following fixed camera models: CC3701H-2, CC3701H-2X, CC3751H-2, CC3651H-2X, MC3651H-2, and CC3651H-2X.
- Three years on all other fixed camera models (including Camclosure® Integrated Camera Systems) and Genex® Series (multiplexers, server, and keyboard).
- Two years on all standard motorized or fixed focal length lenses.
- Two years on Legacy®, CM6700/CM6800/CM8500/CM9500/CM9700 Matrix, DF5 and DF8 Series Fixed Dome products.
- Two years on Spectra®, Esprit®, and PS20 Scanners, including when used in continuous motion applications.
- Two years on Esprit® and WW5700 series window wiper (excluding wiper blades).
- Eighteen months on DX Series digital video recorders and NVR300 Series network video recorders.
- One year (except video heads) on video cassette recorders (VCRs). Video heads will be covered for a period of six months.
- Six months on all pan and tilts, scanners or preset lenses used in continuous motion applications (that is, preset scan, tour and auto scan modes).

Pelco will warrant all replacement parts and repairs for 90 days from the date of Pelco shipment. All goods requiring warranty repair shall be sent freight prepaid to Pelco, Clovis, California. Repairs made necessary by reason of misuse, alteration, normal wear, or accident are not covered under this warranty.

Pelco assumes no risk and shall be subject to no liability for damages or loss resulting from the specific use or application made of the Products. Pelco's liability for any claim, whether based on breach of contract, negligence, infringement of any rights of any party or product liability, relating to the Products shall not exceed the price paid by the Dealer to Pelco for such Products. In no event will Pelco be liable for any special, incidental or consequential damages (including loss of use, loss of profit and claims of third parties) however caused, whether by the negligence of Pelco or otherwise.

The above warranty provides the Dealer with specific legal rights. The Dealer may also have additional rights, which are subject to variation from state to state.

If a warranty repair is required, the Dealer must contact Pelco at (800) 289-9100 or (559) 292-1981 to obtain a Repair Authorization number (RA), and provide the following information:

1. Model and serial number
2. Date of shipment, P.O. number, Sales Order number, or Pelco invoice number
3. Details of the defect or problem

If there is a dispute regarding the warranty of a product which does not fall under the warranty conditions stated above, please include a written explanation with the product when returned.

Method of return shipment shall be the same or equal to the method by which the item was received by Pelco.

RETURNS

In order to expedite parts returned to the factory for repair or credit, please call the factory at (800) 289-9100 or (559) 292-1981 to obtain an authorization number (CA number if returned for credit, and RA number if returned for repair).

All merchandise returned for credit may be subject to a 20% restocking and refurbishing charge.

Goods returned for repair or credit should be clearly identified with the assigned CA or RA number and freight should be prepaid. Ship to the appropriate address below.

If you are located within the continental U.S., Alaska, Hawaii or Puerto Rico, send goods to:

Service Department
Pelco
3500 Pelco Way
Clovis, CA 93612-5699

If you are located outside the continental U.S., Alaska, Hawaii or Puerto Rico and are instructed to return goods to the USA, you may do one of the following:

If the goods are to be sent by a COURIER SERVICE, send the goods to:

Pelco
3500 Pelco Way
Clovis, CA 93612-5699 USA

If the goods are to be sent by a FREIGHT FORWARDER, send the goods to:

Pelco c/o Expeditors
473 Eccles Avenue
South San Francisco, CA 94080 USA
Phone: 650-737-1700
Fax: 650-737-0933

REVISION HISTORY

Manual #	Date	Comments
C1642M	11/04	Original version.
C1642M-A	1/05	Revised Figure 1, added Figures 7-12, and updated wall clip and optical power budget table.

Pelco, the Pelco logo, Coaxitron, Spectra, Genex, Legacy, Esprit, and Camclosure are registered trademarks of Pelco. ExSite and Spectra III are trademarks of Pelco.
©Copyright 2005, Pelco. All rights reserved.



Worldwide Headquarters
3500 Pelco Way
Clovis, California 93612 USA

USA & Canada
Tel: 800/289-9100
Fax: 800/289-9150
International
Tel: 1-559/292-1981
Fax: 1-559/348-1120

www.pelco.com

ISO9001